



Axxicon Multi Format Mould: breakthrough in flexibility and productivity

State-of-the-art production technology helps replicators to cut costs and maximize productivity. Axxicon is dedicated to provide only the single best technology. The latest example of that is the new Multi Format Mould – a single mould that can produce both CD and DVD discs. This leads to big time savings and increasing productivity on lines where frequent format changeovers are required. This way constantly changing customer orders can be handled with the lowest possible downtime.



KNOW-HOW

TO PERFORM



High flexibility in disc production

The Multi Format Mould gives replicators the high level of flexibility they need on their disc production lines. The mould is designed for use in downstream production environments that can produce both CD's and DVD's.

It is also possible to upgrade your own mould to this Multi Format configuration for both hardcut and softcut applications.

AXXICON

we're in it for you



**High
Flexibility**

**Lowest
possible downtime**

Lowest possible downtime for format changes

With Axxicon's new Multi Format Mould there is no longer any need for mould changes and the associated downtime. All that is required is to change the cavity ring which determines the cavity height. This change can be done without removing the mould from the injection moulding machine and takes only a few minutes. For hardcut the punch needs to be repositioned to CD or DVD position. The major advantage is that both formats can be produced with the existing optimized process settings. So replicators get the best of both worlds: maximum productivity without making concessions in disc quality.

Features and Benefits

- Based on well-known, reliable ST mould series.
- Cavity height can be changed easily by only changing cavity ring (from mould front side), without removing the mould from the injection moulding machine.
- Stamper diameter Ø22 for both CD and DVD.
- Stacking ring in both DVD Substrates.
- Competitive cycle times for CD and DVD

Axxicon Moulds Eindhoven

Axxicon Moulds in Eindhoven, the Netherlands, is fully dedicated to Optical Disc developments and offers its customers an outstanding and highly personal worldwide after-sales service through its facilities in Eindhoven and Los Angeles. For more information, please visit our website: www.axxicon.com.

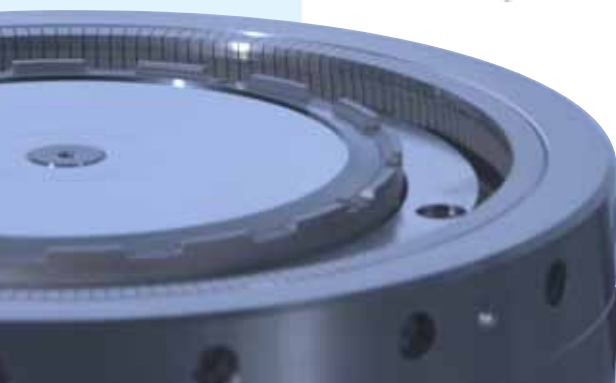
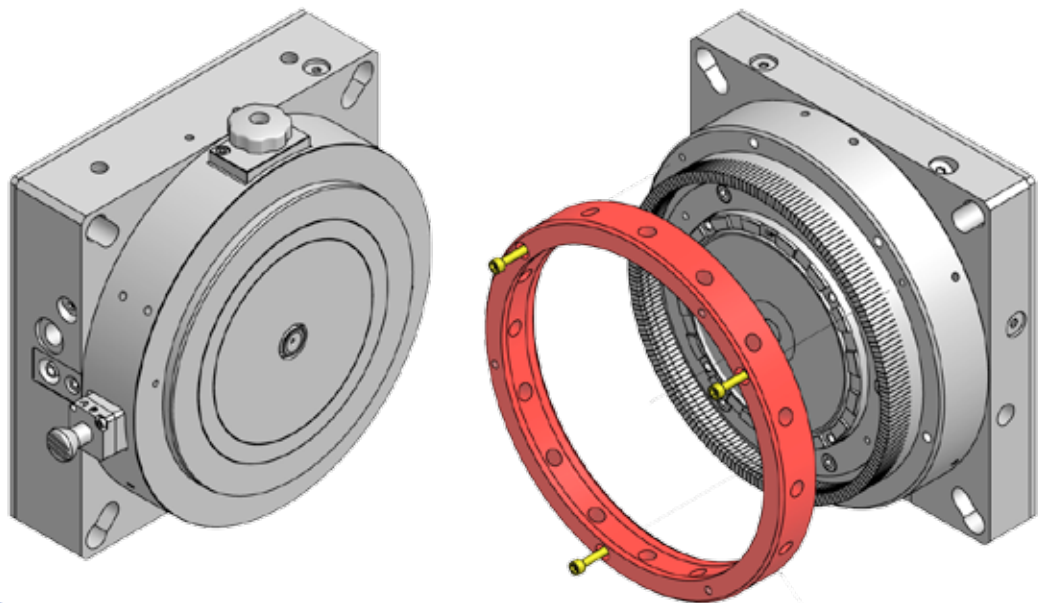

AXXICON

we're in it for you

Europe - The Netherlands
Axxicon Moulds
Eindhoven BV
+31 499 494 450
eindhoven@axxicon.com

North America - USA
Axxicon Molds
Los Angeles Inc.
+1 949 715 0229
losangeles@axxicon.com

www.axxicon.com