

AXXICON CHECK LIST FOR AIM MOULD BASE



www.axxicon.com

Axxicon Quotation Number Q _____
Revision Number _____

Company name _____
Country _____
Contact Person _____
Email _____

Date _____
Agent _____
Contact Person _____
Email _____

MOULD BASE	HOLE PATTERN	BOLT SIZE	MACHINE DRAWING ATTACHED?
<input type="radio"/> Horizontal <input type="radio"/> Vertical	<input type="radio"/> Euomap <input type="radio"/> SPI <input type="radio"/> Other: _____	<input type="radio"/> M12 <input type="radio"/> M16 <input type="radio"/> Other _____	<input type="radio"/> Yes <input type="radio"/> No

INJECTION MOULDING MACHINE	OPTIONS
<input type="radio"/> Machine type/brand _____ <input type="radio"/> Clamping Force _____ <input type="radio"/> Locatingring Ø _____ mm <input type="radio"/> Ejector rod-Yes/No _____ <input type="radio"/> Min. shot volume _____ cm3	<input type="radio"/> Installation and Training € 90/hr + travel <input type="radio"/> Maintenance kit € .. <input type="radio"/> First aid kit € .. <input type="radio"/> Coupling kit € .. <input type="radio"/> Other _____

MOULD TEMPERATURE	RELEASE AND SECURE OF INSERTS
<input type="radio"/> 10-140 °C (Low temperature - water / oil) <input type="radio"/> 140-200 °C (High temperature - water / oil)	<input type="radio"/> Mechanical locking system (standard) <input type="radio"/> Pneumatic cylinder

EXAMPLE OF MACHINE PLATE DETAILS TO BE PROVIDED

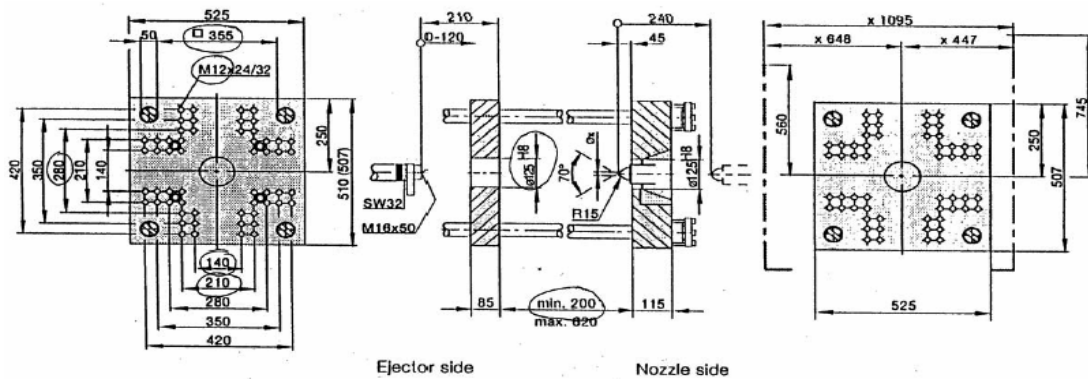

NOZZLE REQUIREMENTS

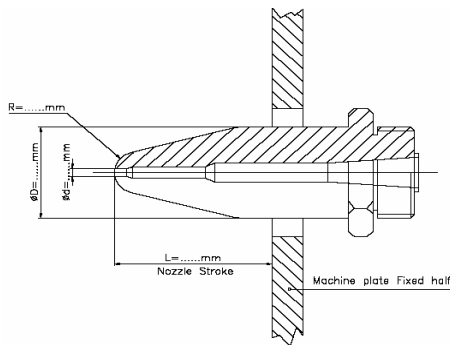

- Length nozzle stroke L _____ mm
- Radius of nozzle R _____ mm
- Outer diameter D Ø _____ mm
- Orifice diameter d Ø _____ mm

REMARKS

Please return this data sheet to your local agent or to: a.lavrijsen@axxicon.com